

Enclosures

Hinges

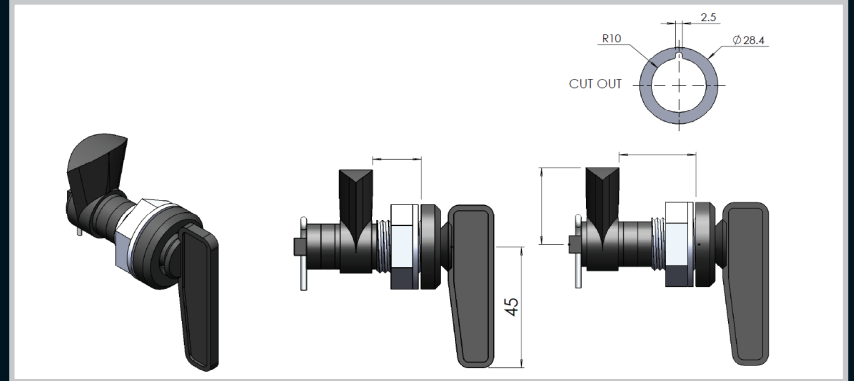

Locks

Remarks:
Mini lever lock with adjustable depths, refer to page 159 for cam selection.

Part Number	Description	L (mm)	H (mm)	H1 (mm)
20_7_331_01	ZDC body and lever, Black powder coated	30	17	28
20_7_561_01	ZDC body and lever, Black powder coated	30	17	45
20_7_331_04n/z	ZDC body and lever, Black powder coated	34	7	43
20_7_561_04n/z	ZDC body and lever, Black powder coated	34	7	59
20_7_331_05n/z	ZDC body and lever, Black powder coated	48	6	43
20_7_561_05n/z	ZDC body and lever, Black powder coated	48	6	59
20_7_331_06P	ZDC body and lever, Black powder coated	49	13	35
20_7_561_06	ZDC body and lever, Black powder coated	49	13	49
20_7_331_08	ZDC body and lever, Black powder coated	49	13	35
20_7_561_08	ZDC body and lever, Black powder coated	49	13	49
20_7_331_09n/z	ZDC body and lever, Black powder coated	37	18	33
20_7_561_09n/z	ZDC body and lever, Black powder coated	37	18	48

Handles

Accessories

Rotary Operating Handles

Insulators

Transformer Equipment

Index

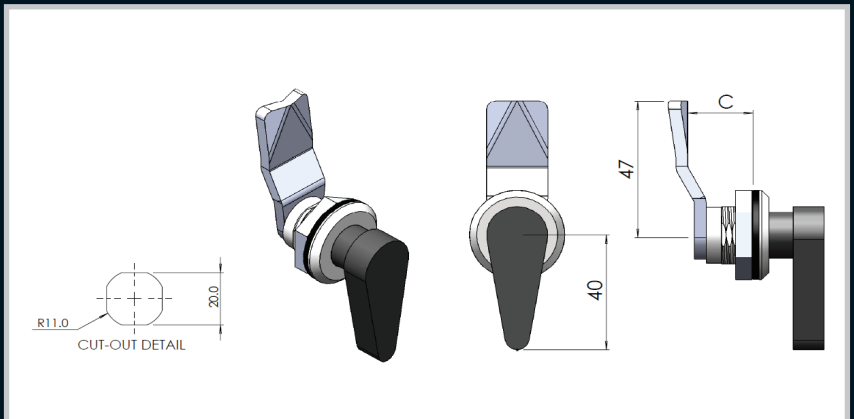

Remarks:
Mini lever lock with adjustable depths, refer to page 159 for cam selection.

Part Number	Description	L (mm)	H (mm)
T26_20	ZDC Body with stainless steel cam	47	20
T26_22	ZDC Body with stainless steel cam	47	22
T26_25	ZDC Body with stainless steel cam	47	25
T26_36	ZDC Body with stainless steel cam	47	36
T26_41	ZDC Body with stainless steel cam	47	41
T26_45	ZDC Body with stainless steel cam	47	45